

PROLUXE™

PROLUXE.COM

NEW!

Non-slip Toasting Perfection

THE ULTIMATE TOASTING SOLUTION

Toast every bun to perfection! The unique patented design toasts both bun halves without falling through. This grips each bun for a golden brown bun every time.

PROMATIC VERTICAL CONTACT
CONTACT TOASTER SINGLE LANE
CT200

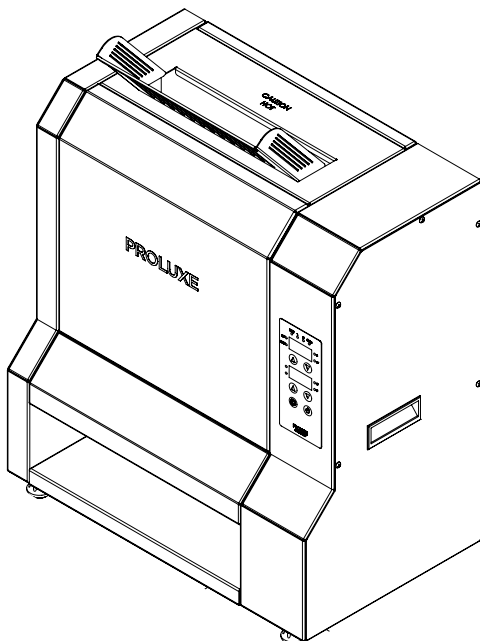

One Toaster for All

The patented SureGrip™ conveyor belt design handles anything from hamburger buns to tortillas, ensuring consistent results every time.

- UP TO 4" x 1.5" BUNS
- EASY FEED VERTICAL DESIGN
- FLEXIBLE SILICONE BELT

SINGLE LANE

ProMatic Vertical Contact Bun Toaster

CT200

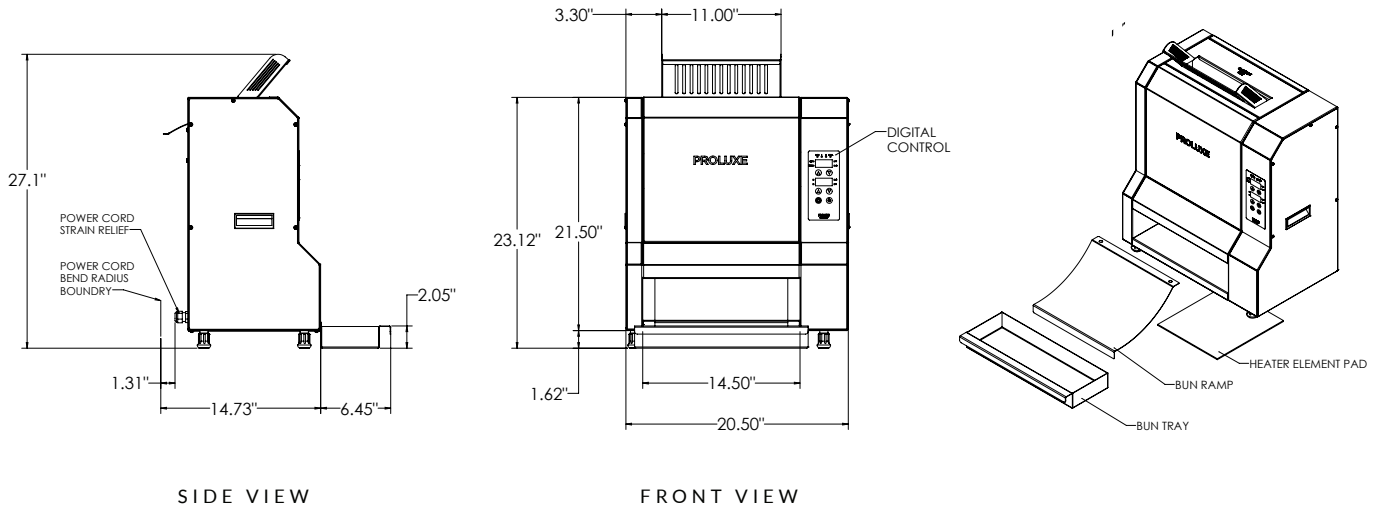

Equipment Details

Temperature Control	Yes	Shipping Weight	TBD
Maximum Heat	600°F/315°C	Machine Weight	83lbs/37kg
Programmable Timer	Yes	Voltage	208/230
Thickness Adjustment	No	Wattage	2404/3300
Belt Speed Control	Yes	Hertz	60
Power Plug	NEMA 6-20P	Amps	12/14
On/Off Switch	Yes	Patent	Pending

PROLUXE™

CORPORATE HEADQUARTERS
20281 HARVILL AVE. PERRIS, CA 92570

HELPING COMMERCIAL KITCHENS
PRODUCE GREAT FOOD FASTER

ADVICE AND SUPPORT
1-800-624-6717